

AUTOMATION TECHNOLOGIES

TELESCOPIC
CONVEYORS

bermak





INSPIRED BY NATURE'S MASTER OF ADAPTATION

THERE IS MODEL ORGANISM OUT THERE FOR OUR TECHNOLOGIES

With Berrmak, you're not just getting advanced automation technology, you're partnering with a company that blends nature's intelligence with cutting-edge engineering to ensure long-lasting success.

- ▶ Works Independently
- ▶ Adapts Flexibly
- ▶ Senses by Touch
- ▶ Moves Precisely
- ▶ Understands the Environment
- ▶ Coordinates and Collaborates
- ▶ Solves Problems
- ▶ Saves Energy

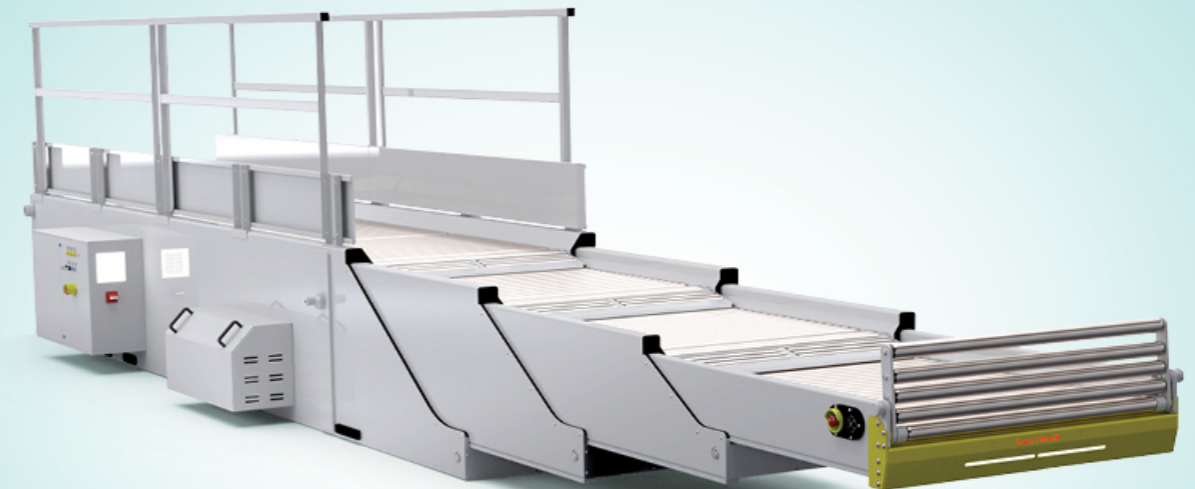

Functions

Furnished with further and custom-made functions to provide flow efficiency, utmost safety, ergonomics and proper communication.

Design

Engineered and especially welded in-house and tailored to users' expectations since 1998. Shaped to fit and forged to provide maximum levels of operator's safety.

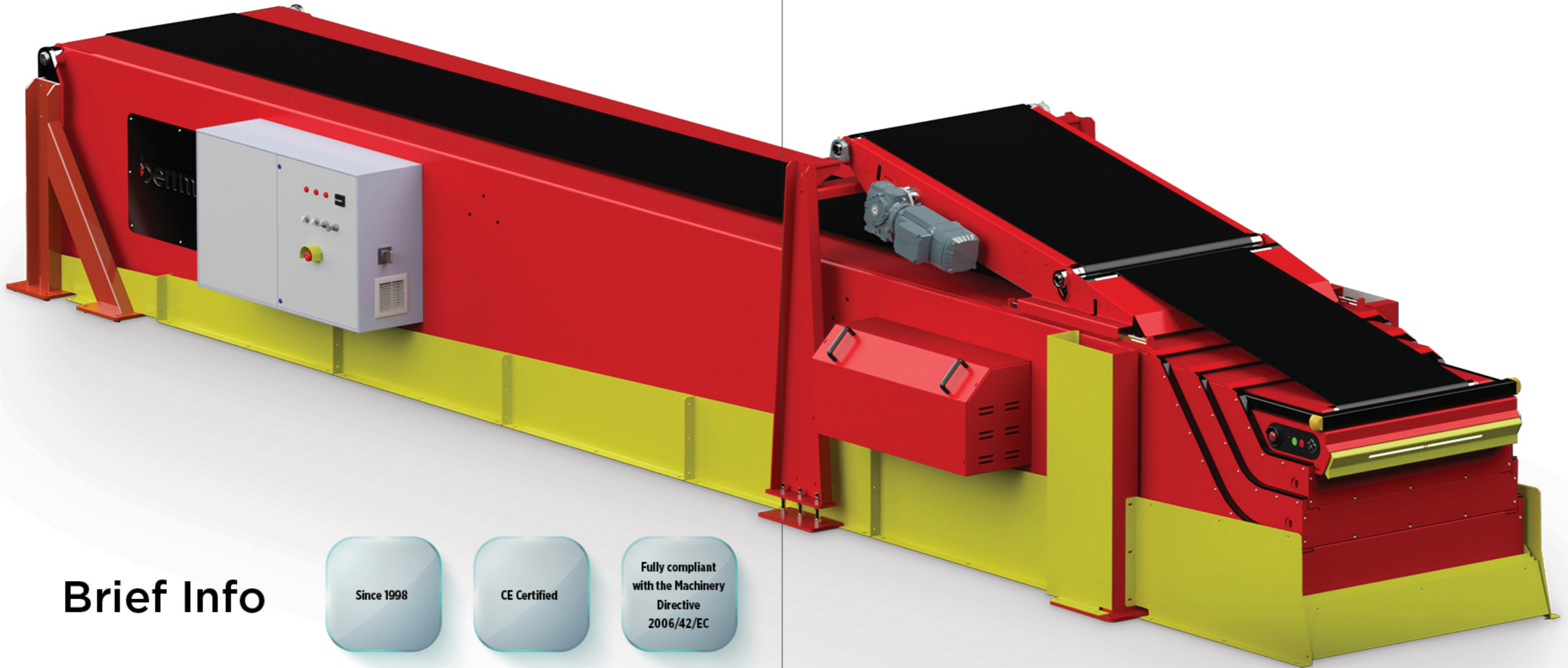

Brief Info

Since 1998

CE Certified

Fully compliant with the Machinery Directive 2006/42/EC

Belted or Gravity Rollers

Safe and efficient loading and unloading functions

PLC based communication interface

Production capacity 1000 pcs/per year

Belt Extendibles



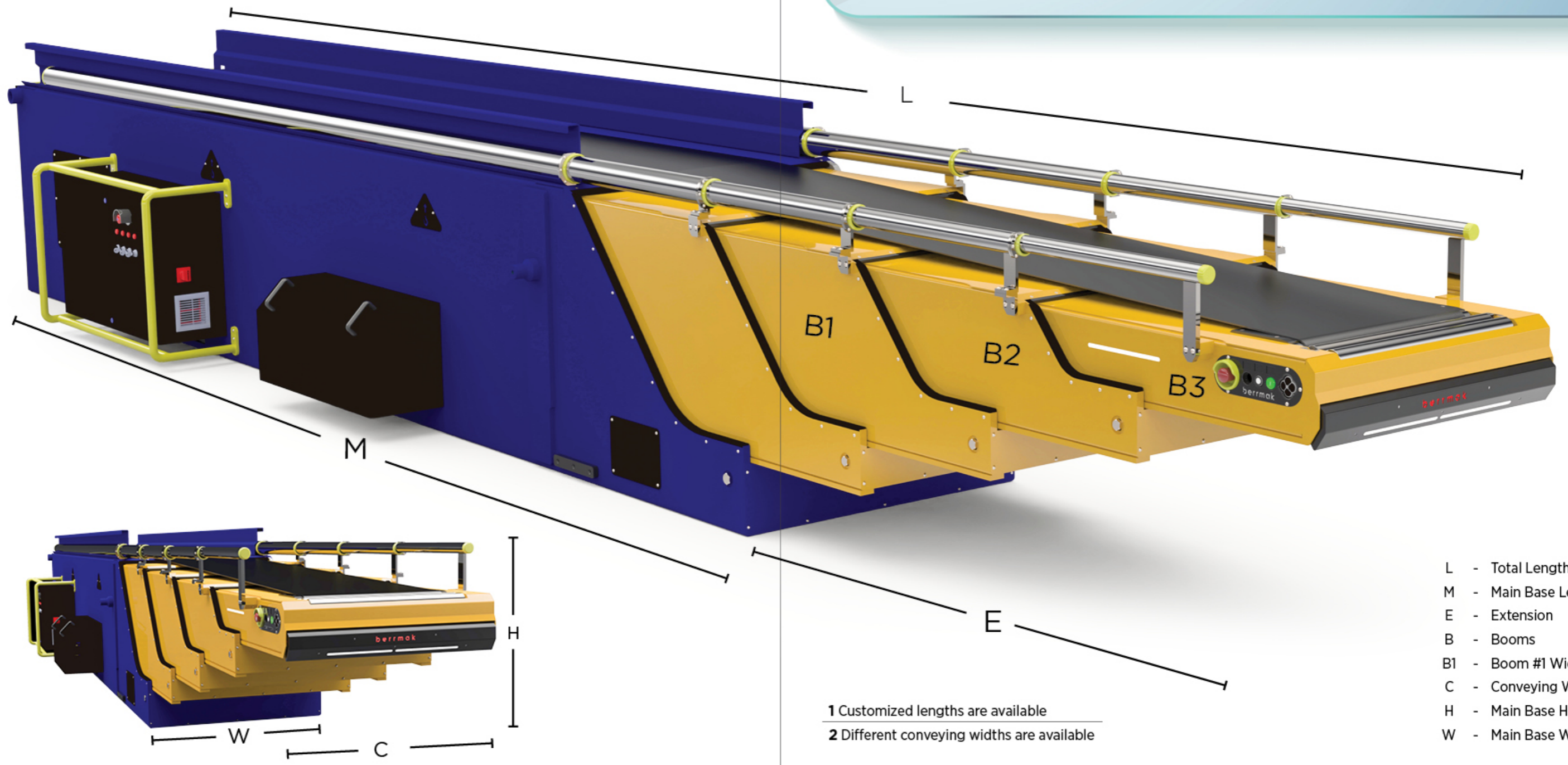

Type	Model No	L ¹ (mm)	M ¹ (mm)	E ¹ (mm)	B	B1	C ²	H (mm)	W
Belted	B-TLS 2,5/1/1/3,5	3.500	2.500	1.000	1	C+286	600/800/1000	550	C+340
Belted	B-TLS 4/3/7/11	11.000	4.000	7.000	3	C+394	600/800/1000	750	C+450
Belted	B-TLS 5/3/10/15	15.000	5.000	10.000	3	C+394	600/800/1000	750	C+450
Belted	B-TLS 6/2/9/15	15.000	6.000	9.000	2	C+340	600/800/1000	600	C+396
Belted	B-TLS 6/3/13/19	19.000	6.000	13.000	3	C+394	600/800/1000	820	C+450
Belted	B-TLS 7,5/3/15/22,5	23.000	7.500	15.000	3	C+394	600/800/1000	820	C+450
Belted	B-TLS 7,5/4/20/27,5	27.500	7.500	20.000	4	C+450	600/800/1000	990	C+505
Belted	B-TLS 9/3/21/30	30.000	9.000	29.000	3	C+394	600/800/1000	750	C+450



- L - Total Length
- M - Main Base Length
- E - Extension
- B - Booms
- B1 - Boom #1 Width
- C - Conveying Width
- H - Main Base Height
- W - Main Base Width

1 Customized lengths are available
 2 Different conveying widths are available

Roller Extendibles

Type	Shape	Model No	L ¹ (mm)	M ¹ (mm)	E ¹ (mm)	B	B1	C ²	H ³ (mm)	W
Gravity Roller		G-TLS 2.3/1/1,5/3,8	3.800	2.300	1.500	1	C+127	600/800/1000	505	C+163
Gravity Roller		G-TLS 5/2/7/12	12.000	5.000	7.000	2	C+164	600/800/1000	642	C+202
Gravity Roller		G-TLS 6/2/8,5/14,5	14.500	6.000	8.500	2	C+164	600/800/1000	642	C+202
Gravity Roller		G-TLS 6/3/13/19	19.000	6.000	13.000	3	C+200	600/800/1000	850	C+242

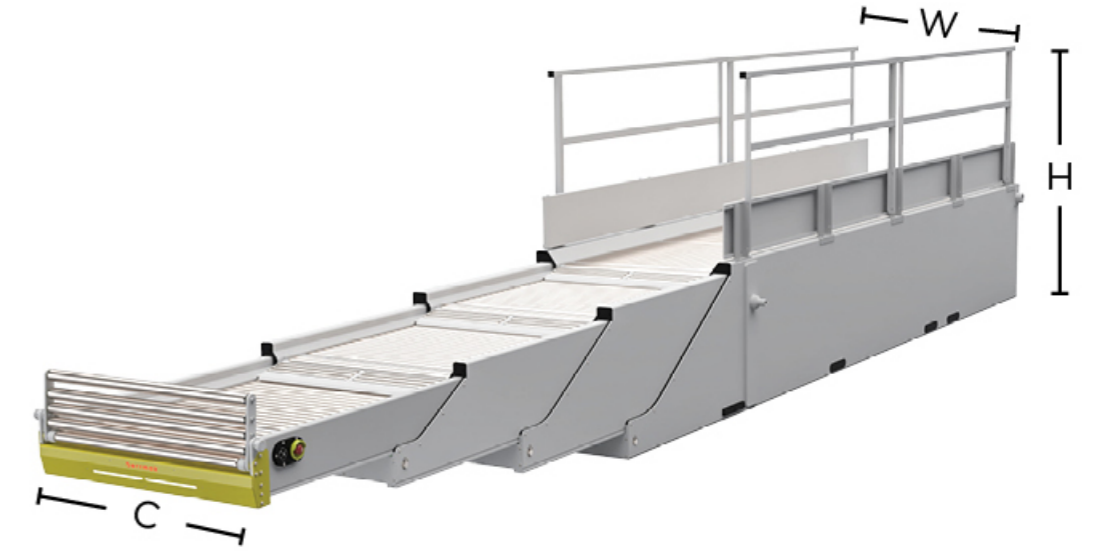
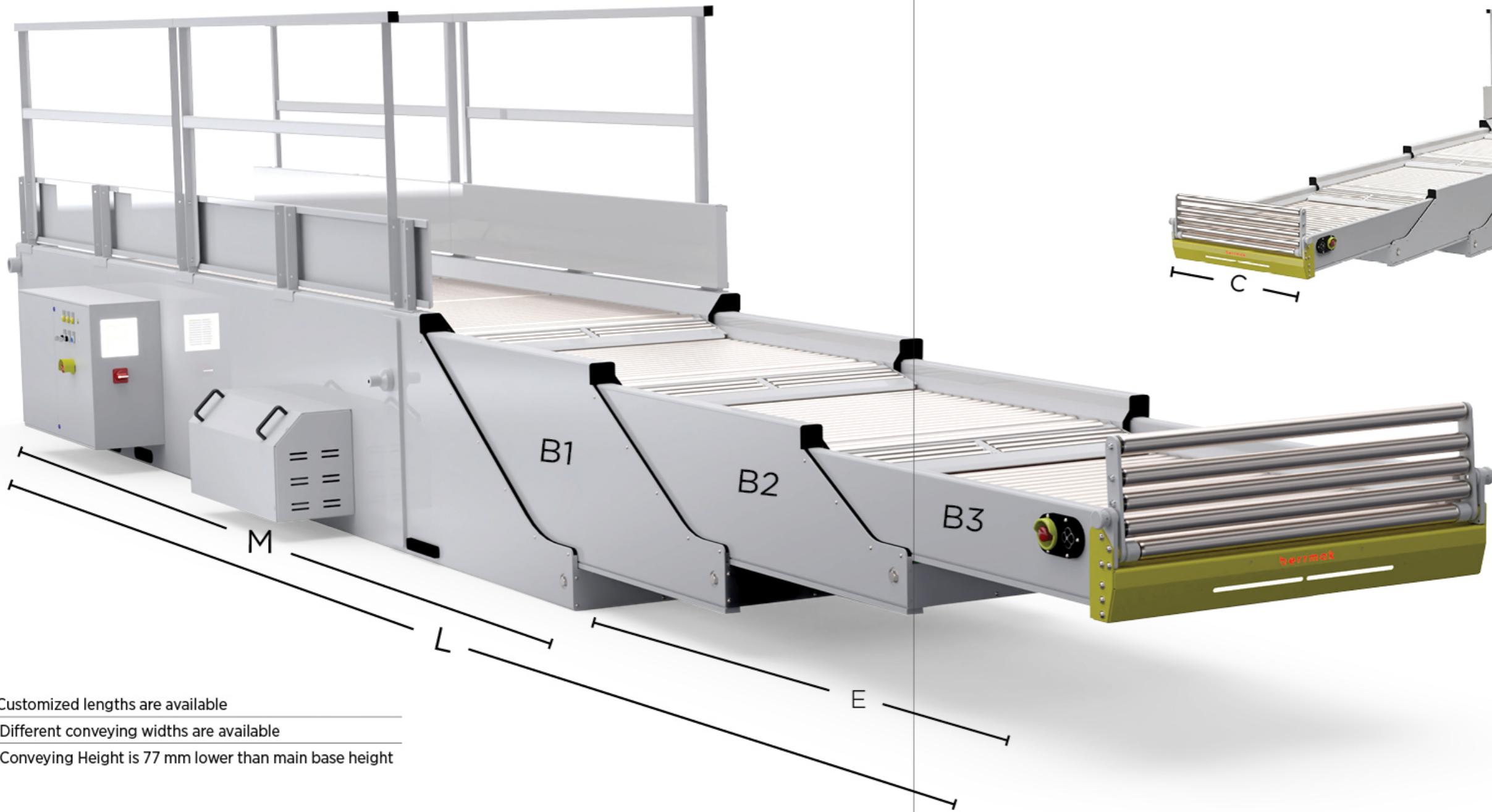

- 1 Customized lengths are available
- 2 Different conveying widths are available
- 3 Conveying Height is 77 mm lower than main base height

- L - Total Length
- M - Main Base Length
- E - Extension
- B - Booms
- B1 - Boom #1 Width
- C - Conveying Width
- H - Main Base Height
- W - Main Base Width

Telescopic Conveyors and Safety

- ▶ Pop-out roller
- ▶ Safety Skirts
- ▶ Safety Crush Bar
- ▶ Chain Flair Detections
- ▶ Pinch Point Protection
- ▶ Always on boom brake system

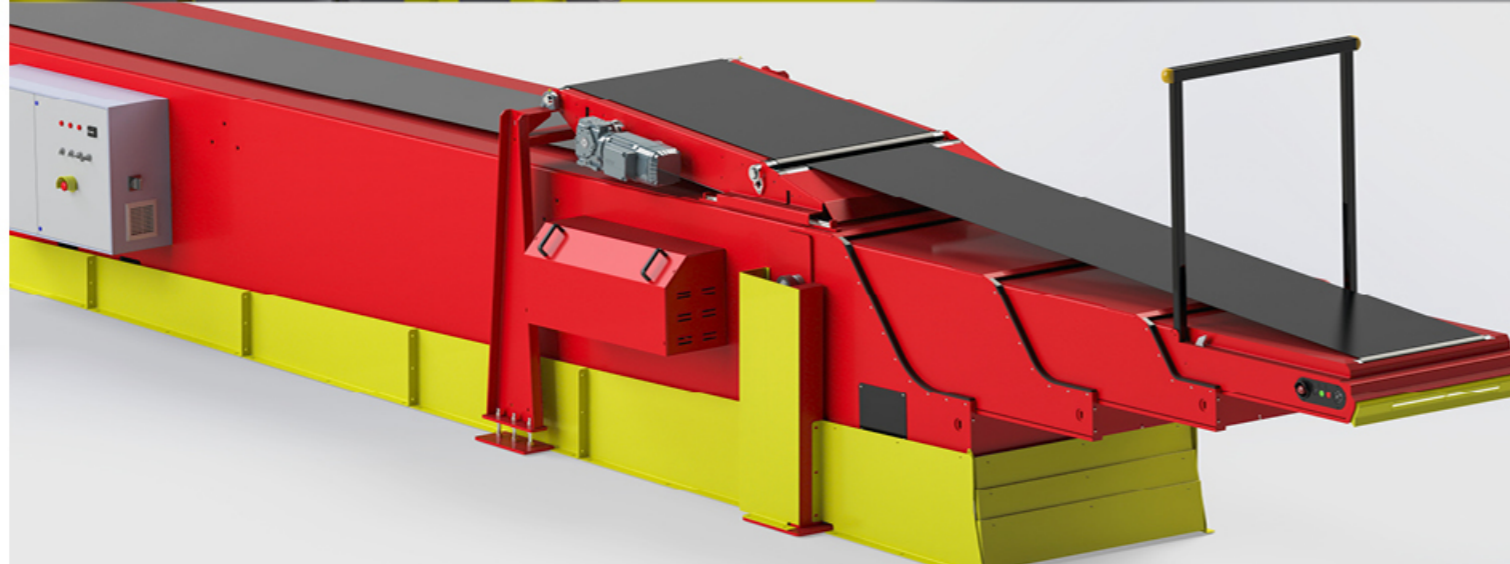
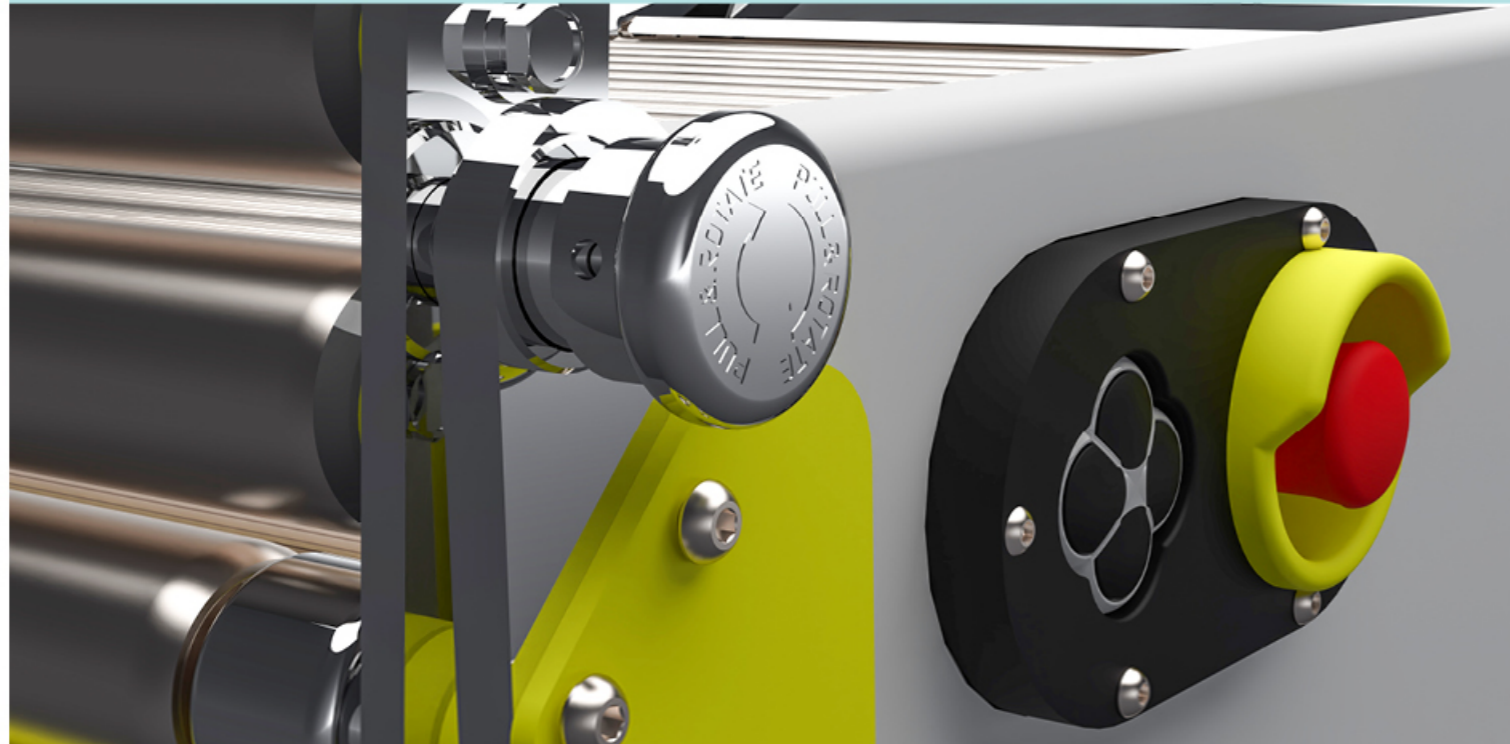

Always on boom brake system

Gravity Roller Telescopic conveyors must remain a minimum 3,5° angle to assure parcel flow. Considering the sufficient angle that may allow booms extend freely in case of a motor or chain failure an always on boom brake system is embedded to all Gravity Roller Extendibles or any belt extendible with a considerable angle.

▶ Pop-out roller

On loading (outfeed) extendibles. Prevents hands being pulled in by drum pulley. When pops-out belt stops immediately.

▶ Pinch Point Protection

All moving parts are covered to allow gaps maximum 4mm.

▶ Safety Crush Bar (Anti-Collision Bar)

On all extendibles. Prevents collisions from front and from bottom. When pushed stops the extension or lowering immediately and pulls/lifts itself back for a few seconds.

▶ Safety Skirts

On Hydraulic tilt adjusted extendibles. Prevents feet going under the unit.

▶ Chain Flair Detection

Instantly reports system flairs through sensors that detect chain breaks.



Additional Functions and Options



▶ Operator Platforms

Operator platforms can be embedded to the front boom. It is commonly used in tire industry. The platform can be equipped with foot pedal buttons if requested.

▶ Lift Aids

Either a vacuum lifter or a snoot to provide further ergonomics can be implemented on extendibles.

▶ Bended Front Boom

It is commonly used on gates where different height of vehicles loaded/unloaded. The front section lowers to maximum 17° angle.

▶ Parcel Flow Efficiency

For flow efficiency, parcel flow can be managed by photo eyes in order to buffer, over-range detections, die-back etc.

▶ Hoods

Hoods can be fixed or sliding based on lift functions and pivot points.

▶ Customized Communication Interface

We process the signals between the system and the conveyor following the customer's request.

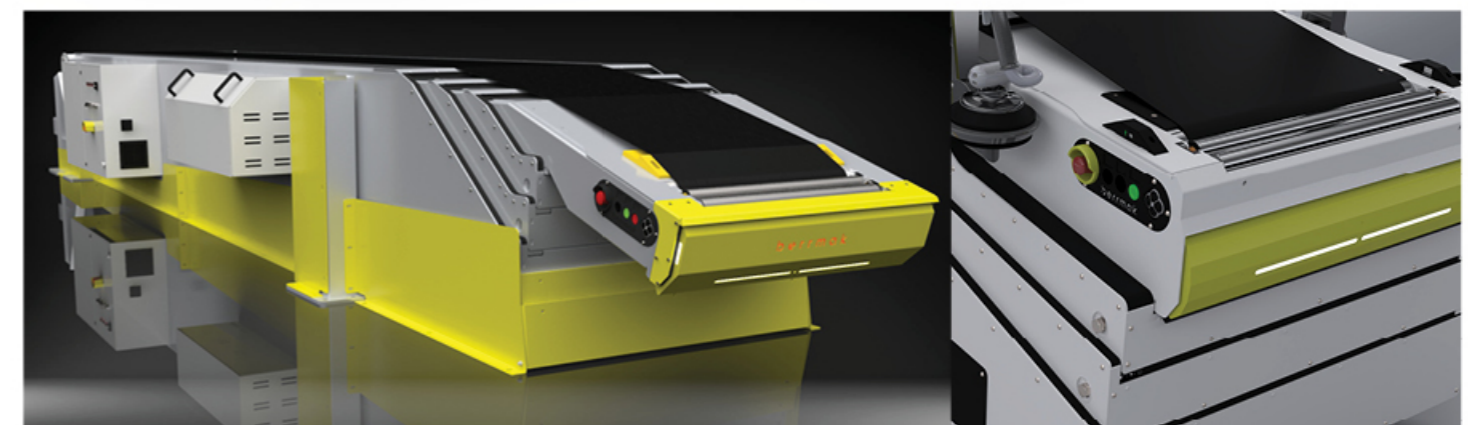
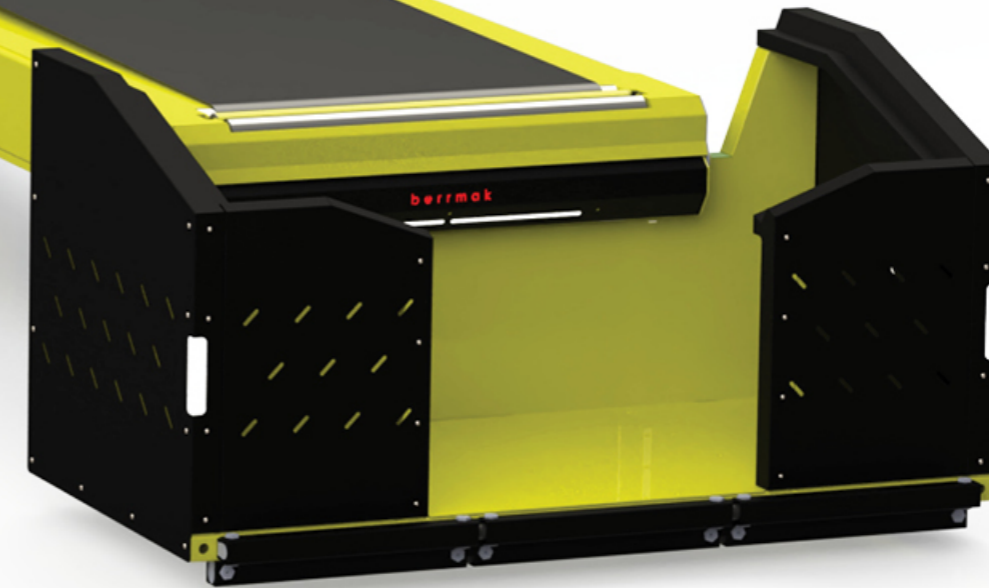

General Specifications

Type	Shape
Main Supply	400 ACV, 3ph+PE+N, 50Hz, 16 A
Transport Speed	0,25 - 0,55 m / sec (Adjustable speed)
Extend Speed	0,20 - 0,30 m / sec
Load Capacity	50 kg / m
Emergency Stop	Both sides of the front boom and one on the control cabinet
Control Voltage	24 VDC
Power Supply Connection	Isolated power supply to be provided by customer
Controls Buttons	Both front sides of the front boom
Safety Crush Bar	2 Way anti-collision protection on the tip of front boom.
Ral Code (Color)	TBD
Control Cabinet Position	Left / Right (Looking from the rear of the machine)
Maintenance Entrance Windows	Left and Right
Safety Pop-Up Roller	On Loading Units
Belt Drive	Drum Motor
*PLC	Yes (Siemens S7 1214)
*Communication Interface	Via hardwired 24VAC Signals
*EMS Interface	Via Safety Relay 24VAC Signals

Berr-Snoot

Berr-Snoot is an additional belt section embedded to the front of telescopic conveyor. By moving upwards and downwards, Berr-Snoot provides operators a more ergonomic and working environment.

During the unloading operation Berr-Snoot is capable of moving up and down to make unloading operation easier. Using this function operator can reach the parcels on the higher or lower levels with unloader. Operator can control Berr-Snoot and telescopic conveyor via the control panels located on each side of Berr-Snoot. Berr-Snoot units can be used for unloading and loading operations.

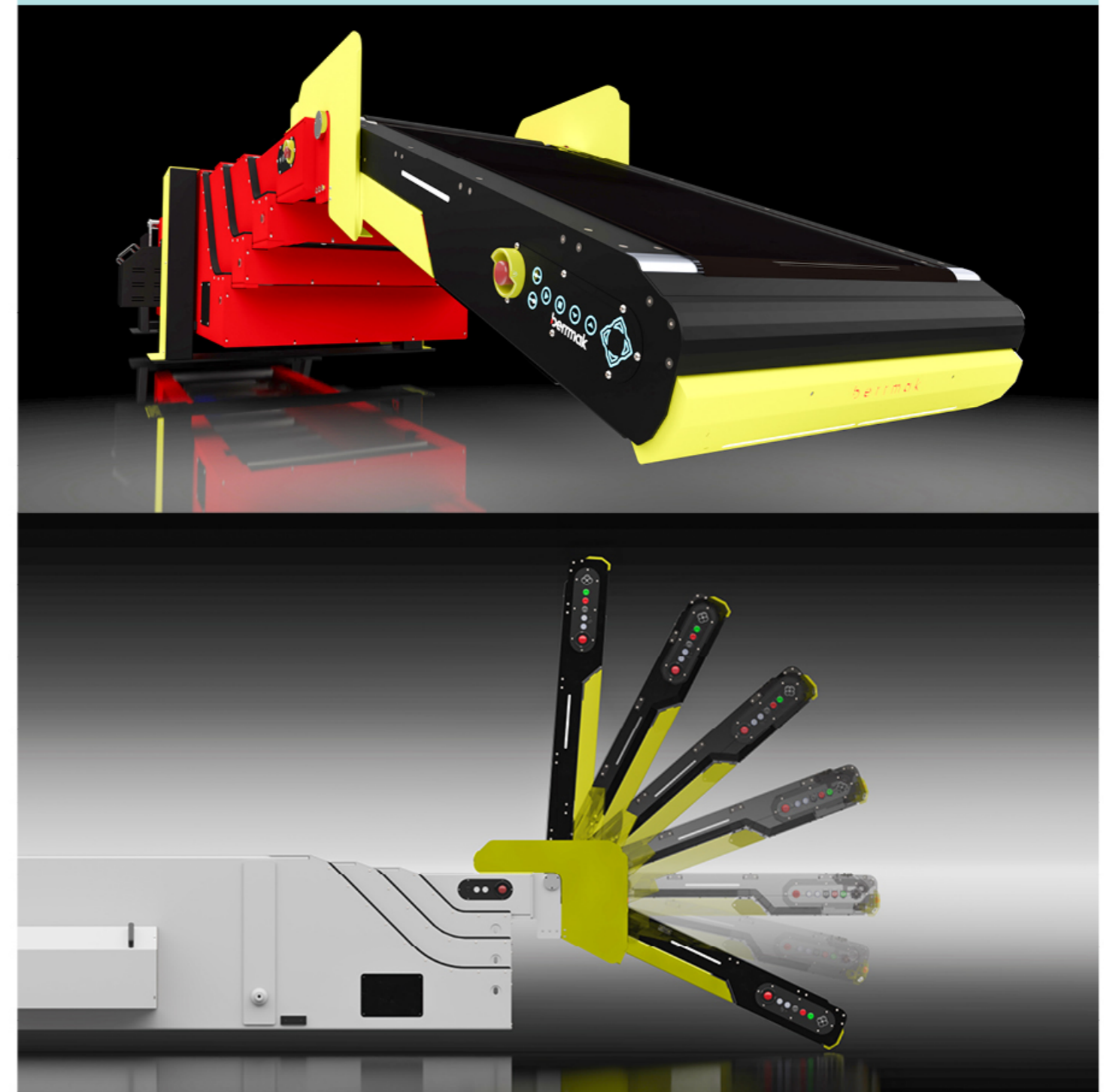

Our Projects Worldwide

We have successfully integrated the Berrmak solution into hundreds of different locations, quickly delivering value and efficiency gains. Our team are experts in understanding your challenges and how Berrmak can help you overcome them.



After Sales Service Support EUROPE

One of Berrmak's strengths is our worldwide after-sales assistance.

Differently from many other realities, we guarantee a complete 360-degree assistance during the whole purchasing process and especially after it: our incredible team provides engineering, technical, and software support, both online and in-person and whenever you need it.



Türkiye
▶ Berrmak HQ

Germany
▶ Berrmak GmbH
▶ Samont Industrieanlagen

The Netherlands
▶ Brouwers Industrial Service

France
▶ Actemium
▶ MS Technologies
▶ PH Facility
▶ SOCAPS

England
▶ IDC

4 Continents



200 More than 200 projects



23 Countries



+ 1000+ product integrations



5 Countries

9 Support partners

25 More than 25 years of experience

Companies trusting in **bermak**

► Logistics



► E-Commerce



► Cargo



► Tyre Industry



► Retail



► Food Industry



► Others









Berrmak Türkiye

İkitelli OSB, Hürriyet Bulvarı,
Deparko Plaza, Kat:3, No:9-10, 34490
Başakşehir, İstanbul
T : +90 212 486 2579

w : www.berrmak.com

Berrmak  

Berrmak Official  



Berrmak Germany

Berrmak GmbH
Friedrichstraße 95
10117 Berlin
T : +49 (0)30 253 26363

w : www.berrmak.de